

R-CAR GEN3 LINUX BUSINESS UPDATE

SUBLINE

JULY 12TH, 2016

TOSHIAKI KOMATSU

OPEN SOURCE DEVELOPMENT CENTER,
AUTOMOTIVE INFORMATION SYSTEM BUSINESS DIV.

1ST SOLUTION BUSINESS UNIT

RENESAS ELECTRONICS CORPORATION

R-CAR H3 WS1.1 BLOCK DIAGRAM

Preliminary

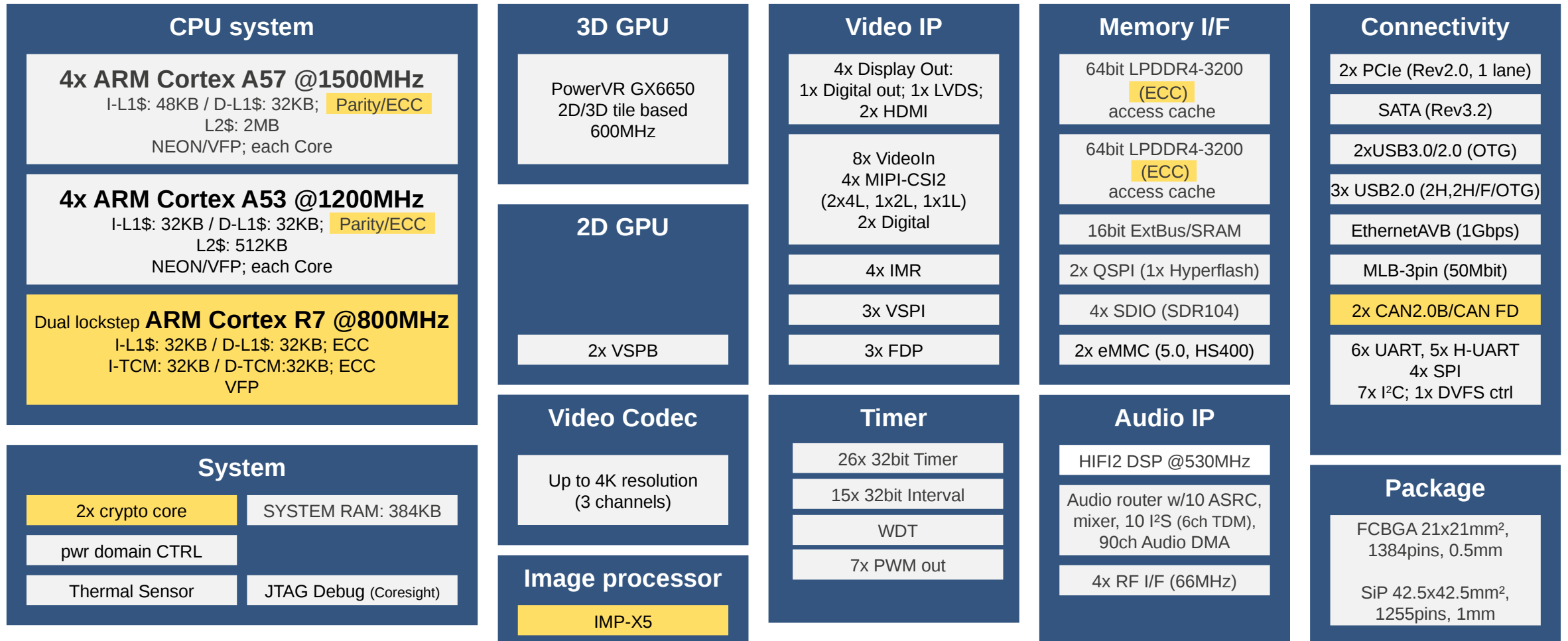
 Optional function

R-CAR H3 WS2.0 BLOCK DIAGRAM

A57(1.5GHz), 3D GPU(600MHz) @0.82V(typ voltage) Power Optimised
 A57(1.6GHz), 3D GPU(600MHz) @0.90V(typ voltage) Normal
 A57(1.7GHz), 3D GPU(600MHz) @0.96V(typ voltage) High Performance

Preliminary

Optional function

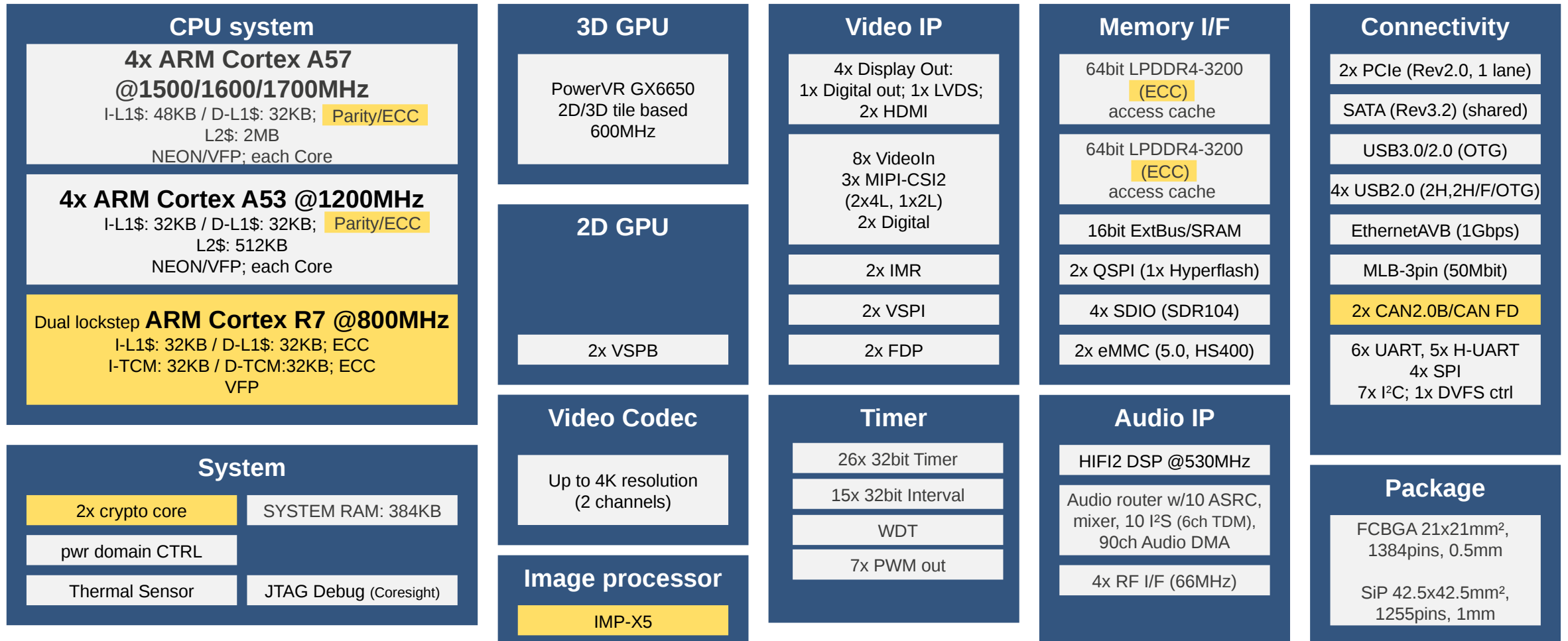

R-CAR M3 BLOCK DIAGRAM

A57(1.5GHz), 3D GPU(600MHz) @0.82V(typ voltage) Power Optimised
 A57(1.7GHz), 3D GPU(600MHz) @0.90V(typ voltage) Normal
 A57(1.8GHz), 3D GPU(700MHz) @0.96V(typ voltage) High Performance

Preliminary

Optional function

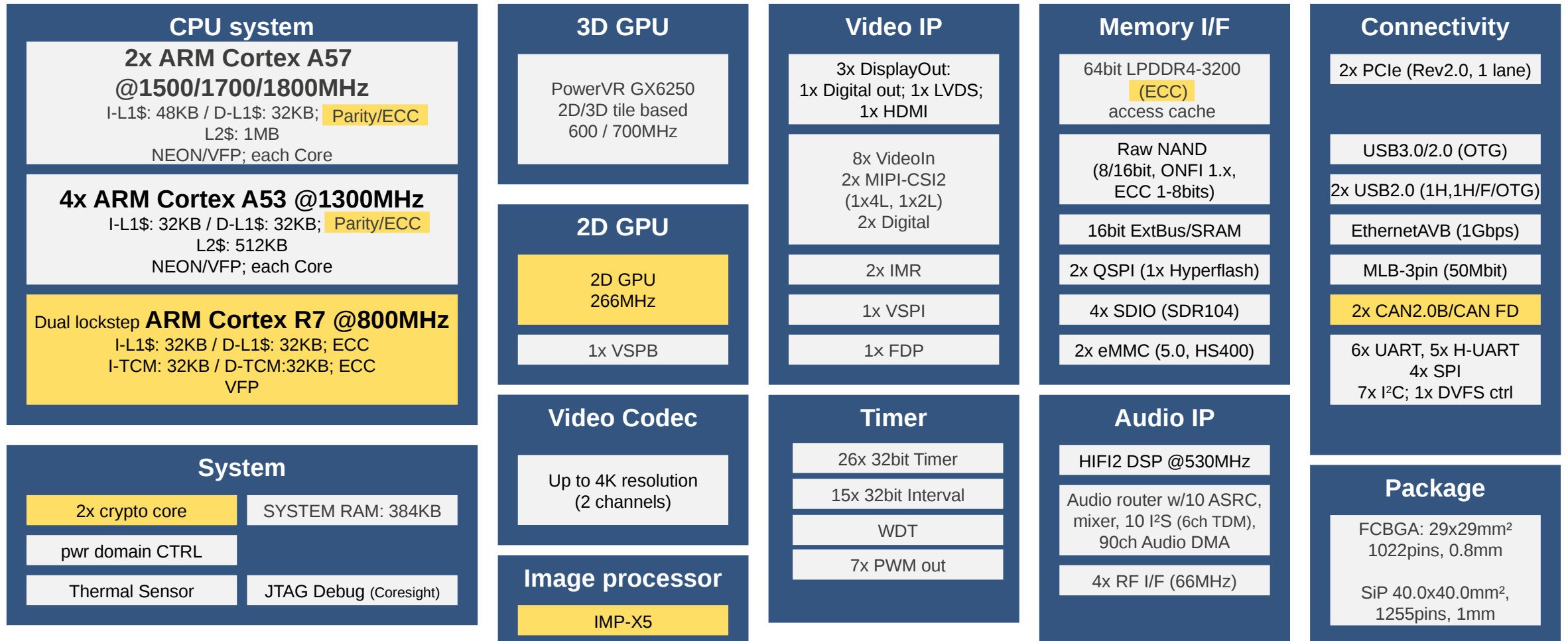

R-CAR M3N BLOCK DIAGRAM

A57(1.5GHz), 3D GPU(600MHz) @0.82V(typ voltage) Power Optimised
 A57(1.7GHz), 3D GPU(600MHz) @0.90V(typ voltage) Normal
 A57(1.8GHz), 3D GPU(700MHz) @0.96V(typ voltage) High Performance

Preliminary

Optional function

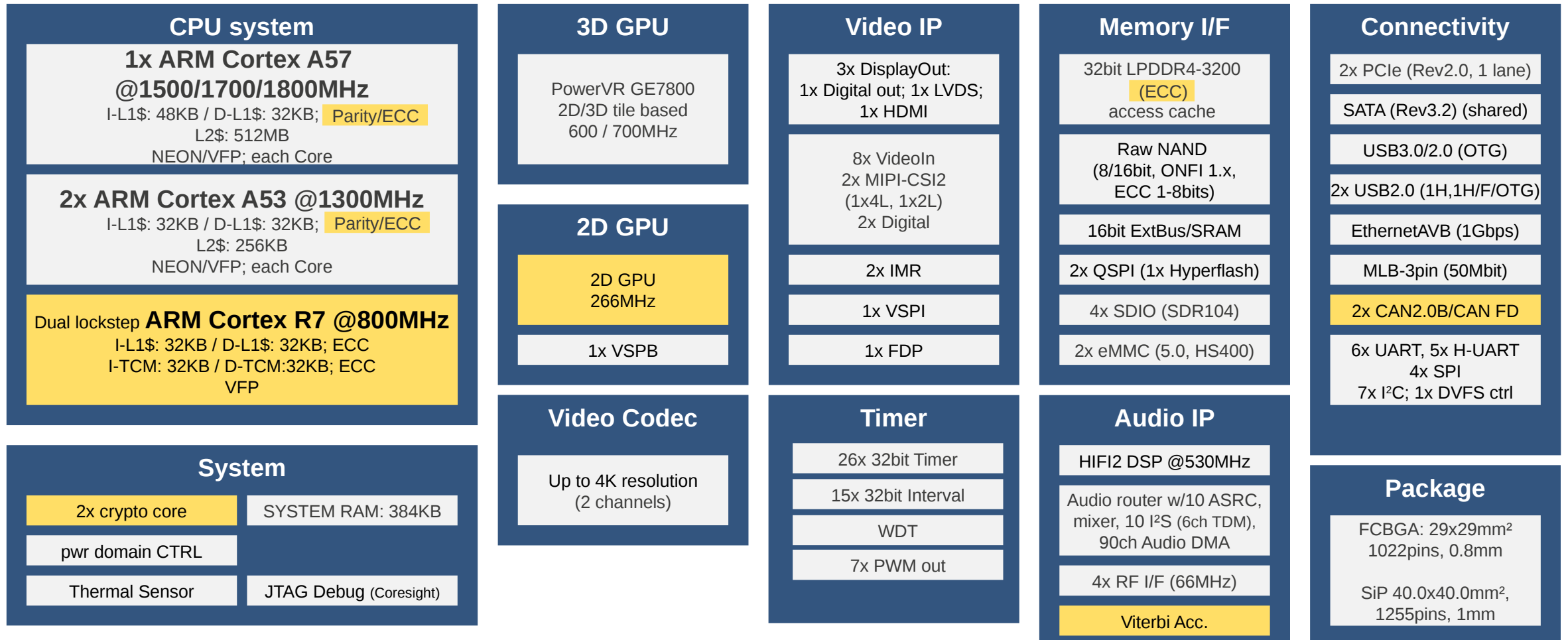

Preliminary

 Optional function

R-CAR E3 BLOCK DIAGRAM

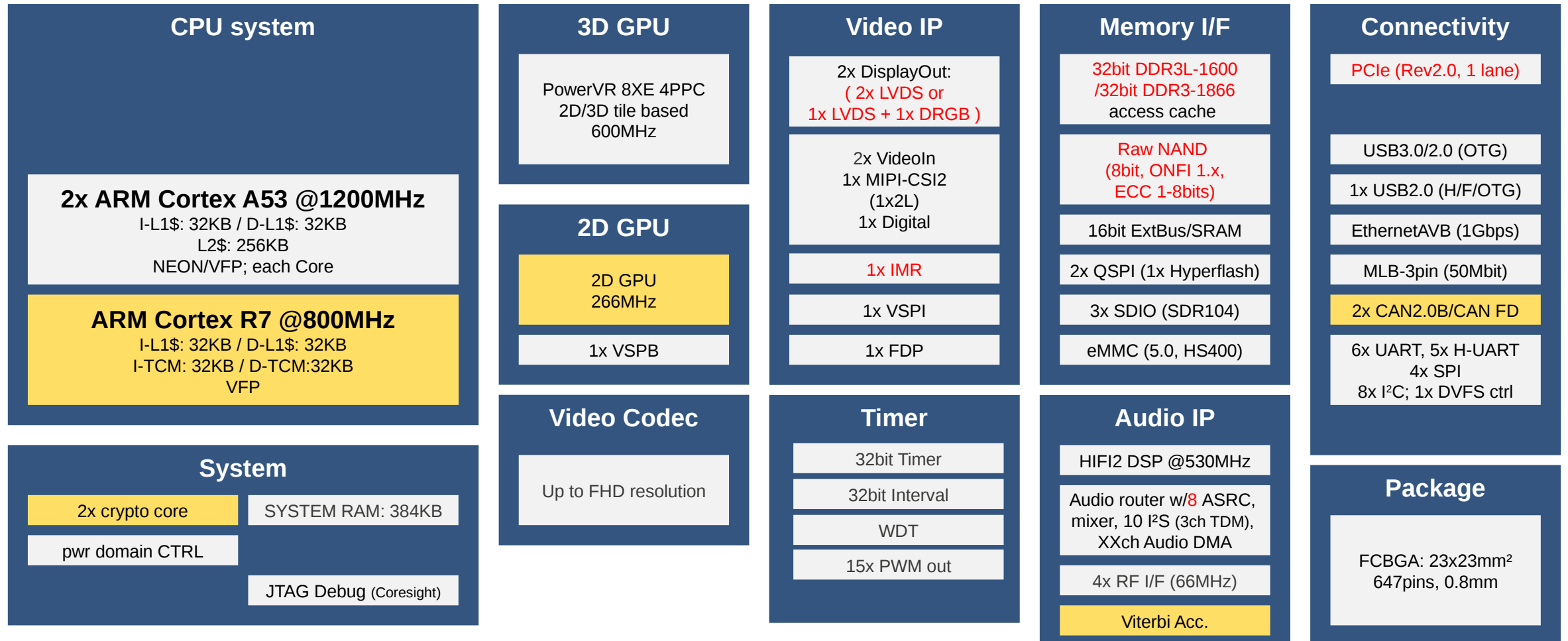

R-Car H3/M3 Software block for Linux (step1) -internal only

2016.4.21 Updated

Keep Gen2 API Compatibility

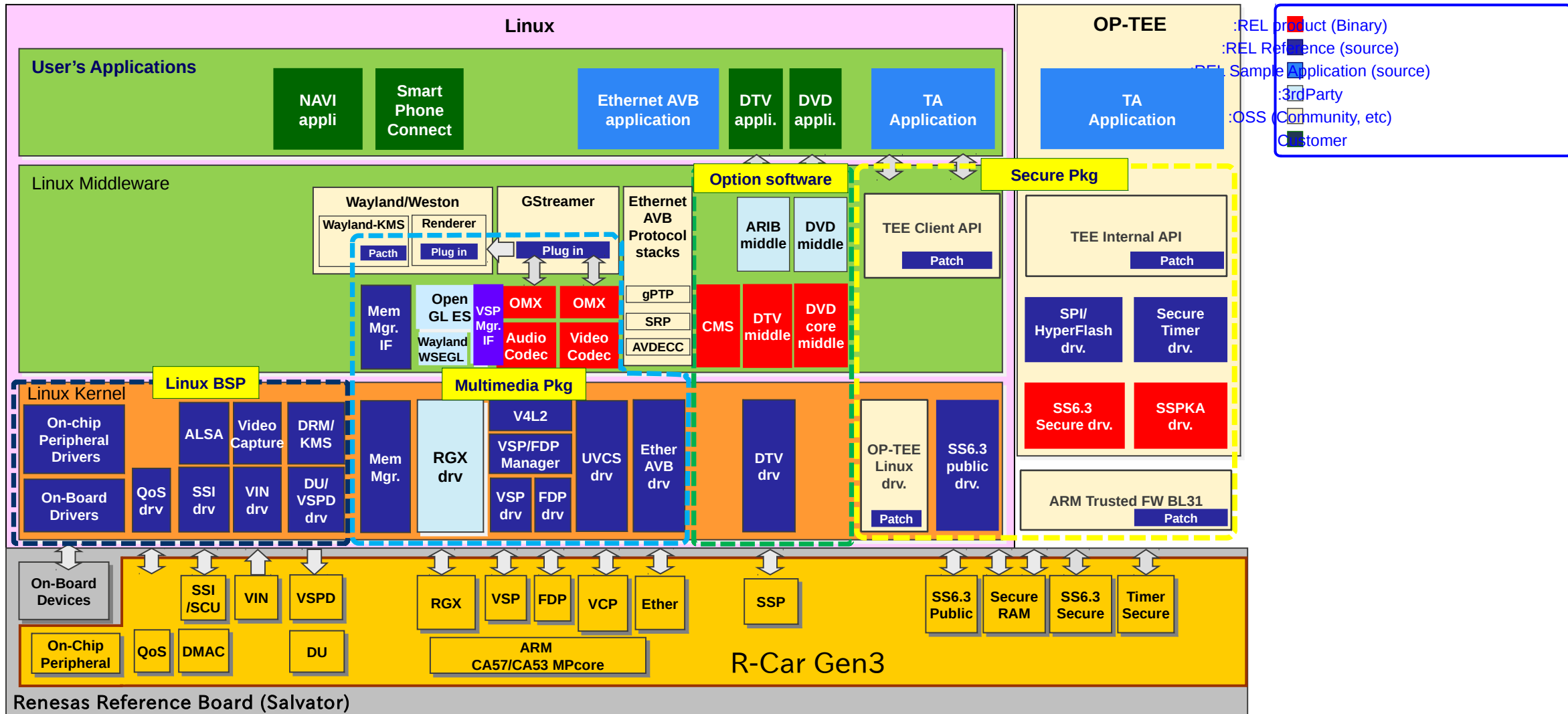

: These APIs are prepared to keep the Gen2 compatibility.

R-CAR GEN3 LINUX PROJECT ORGANIZATION

FY2016 OPEN SOURCE DEVELOPMENT CENTER ORGANIZATION

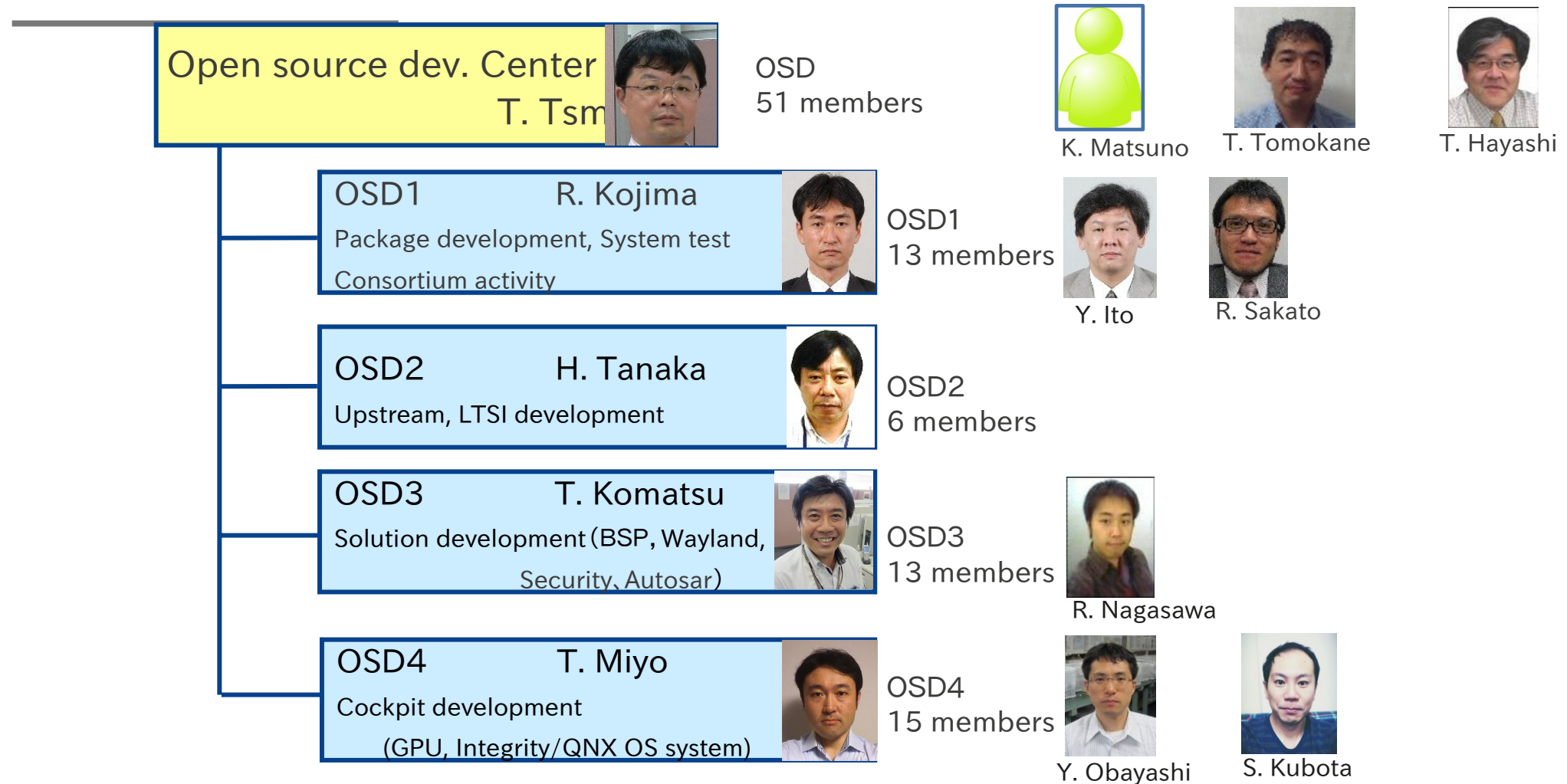

R-CAR GEN3 LINUX OSD ORGANIZATION

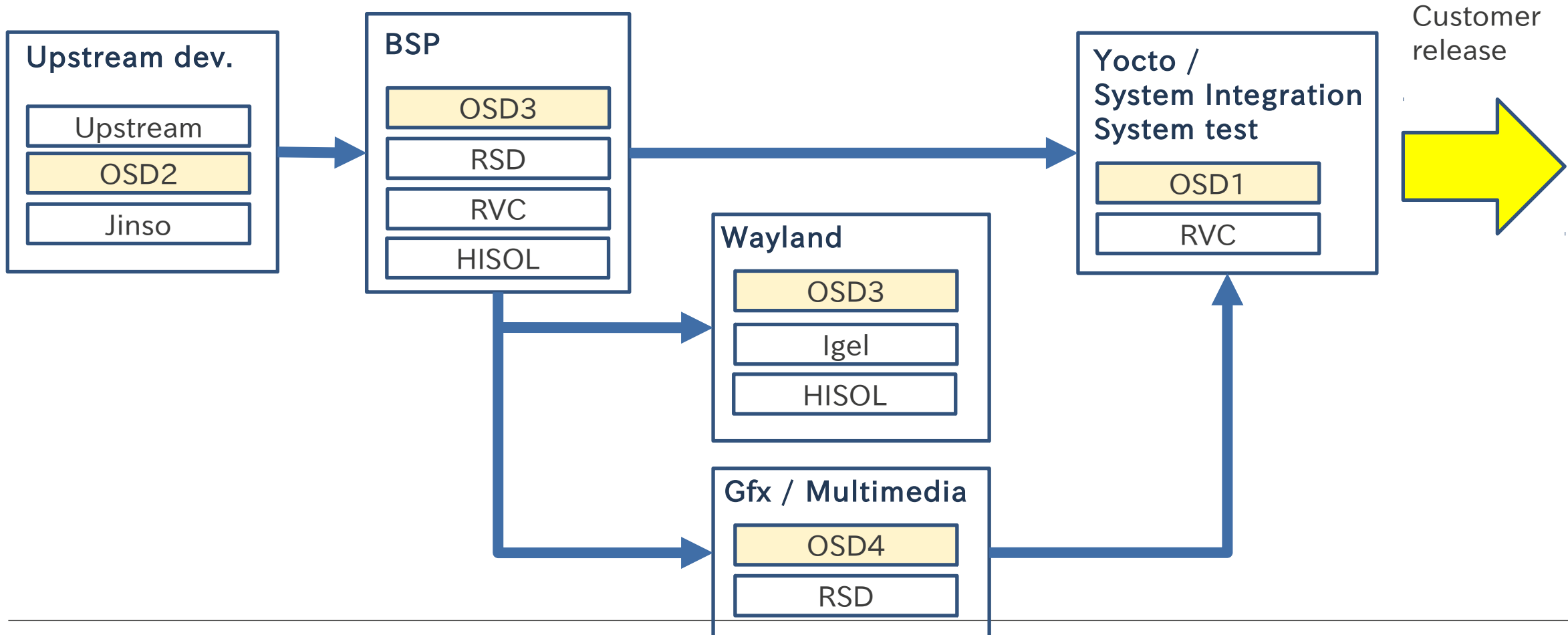

R-CAR H3 UPDATE PLAN

'16.06.22 Updated

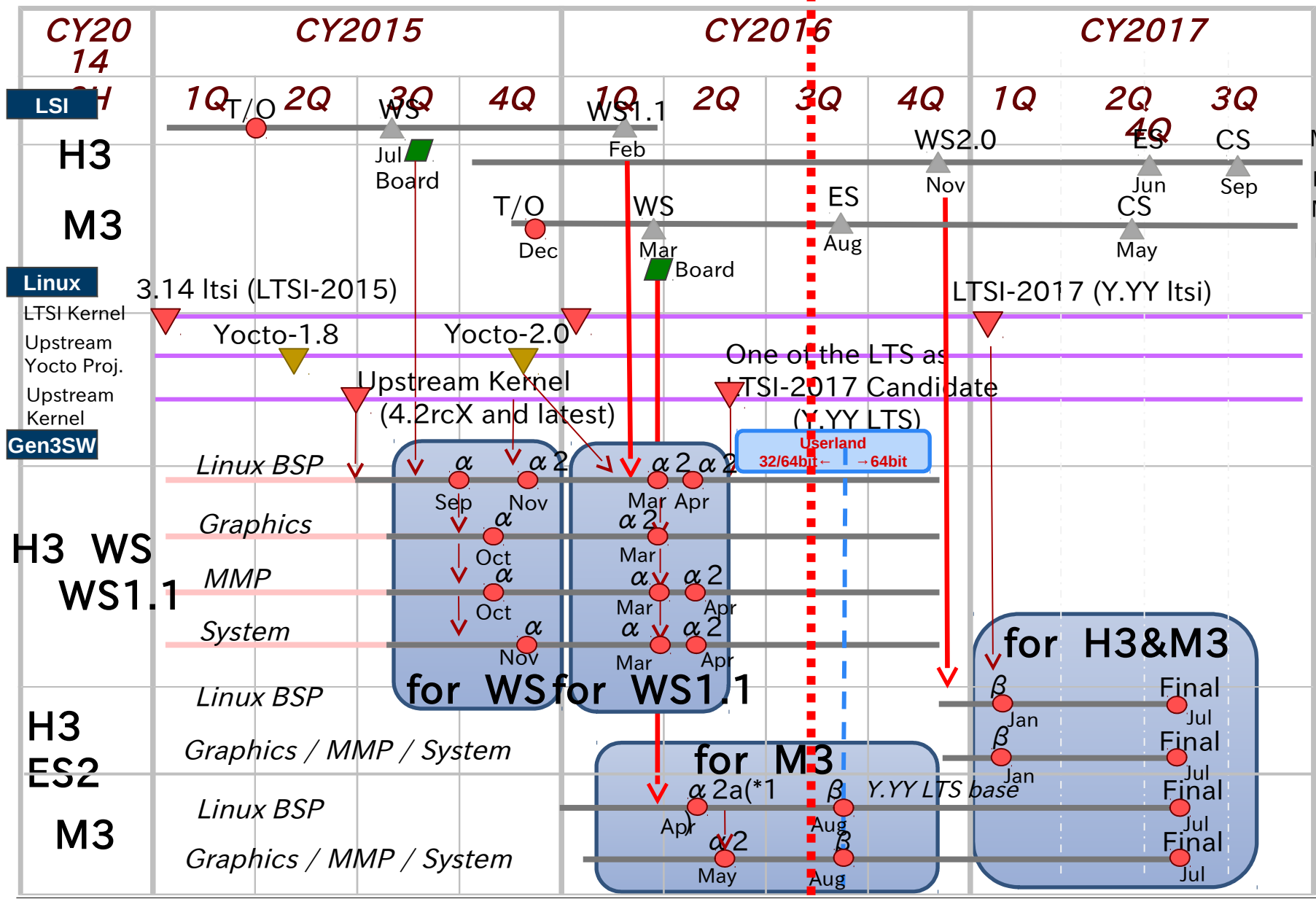

Note: Each schedules basically means "end of the month".
e.g. the schedule of H3 WS Linux BSP release is "end of Sep, 2015".

For exceptions, specific comment will be added.

(*1) M3 release : BSP α 2a is planned one month later from M3 WS. Other SW (e.g. graphics) are planned two month later. Using Salvator-X (Socket type), teams can start M3 confirmation when M3 WS comes.

R-CAR H3/M3/M3N/E3 UPDATE PLAN

Now

Tentative

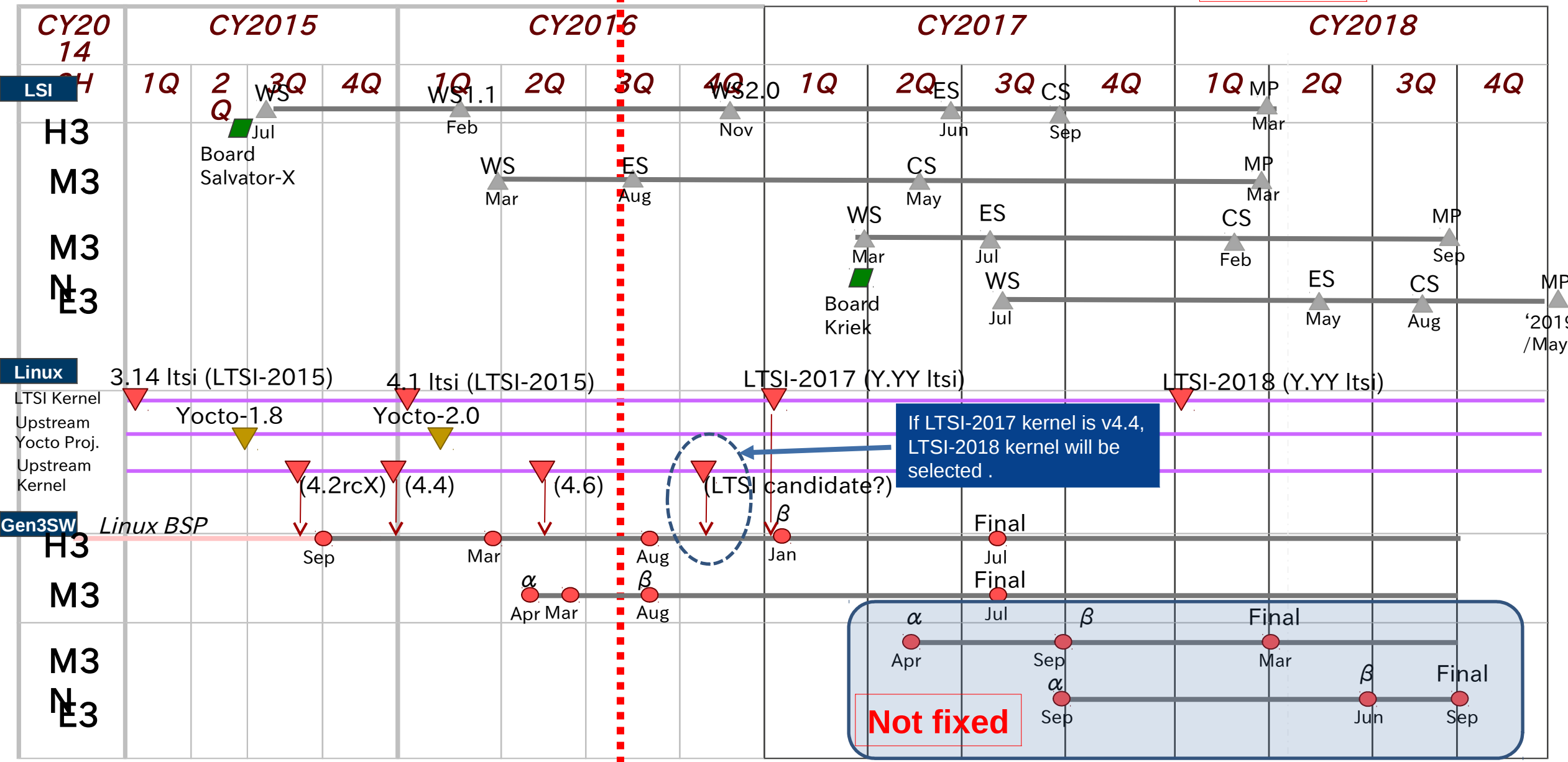

GEN3 LINUX RELEASE VERSION

Internal

Updated

2016.06.22

Yocto Recipe Ver	date	Yocto	Tool chain	Wayland	GStreamer	Kernel Ver (LTSI)	Userland 64/32bit	U-Boot	LSI		Software					Note	
									H3	M3	BSP	Gfx		MMP	System (Secure)		CMS
												H3	M3				
v2.1.0	15/9E	YP1.8	gcc-linaro-4.9-r2015.03	-	-	4.2	32/64	2015.04	WS1.0	-	α	-	-	-	-	-	
v2.2.0	15/10E	↑	↑	1.6	1.4.5	↑	↑	↑	↑	-	↑	α	-	α	-	-	
v2.3.0	15/11E	↑	↑	1.6	↑	↑	↑	↑	↑	-	α2	↑	-	↑	α	-	
v2.4.0	15/12E	↑	↑	1.6	↑	↑	↑	↑	↑	-	↑	↑	-	↑	↑	-	Internal
v2.5.1	16/1E	↑	↑	1.6	↑	4.4rc2	↑	↑	↑	-	↑	α2	-	↑	↑	-	Internal
v2.5.2	16/1E	YP2.0	gcc-linaro-5.1-r2015.08	1.8	↑	4.4rc2	↑	↑	↑	-	↑	α2	-	↑	↑	-	Internal
v2.6.0	16/2E	↑	↑	1.8	↑	4.4rc2	↑	↑	↑	-	↑	↑	-	↑	↑	-	Internal
v2.7.0	16/3E	YP2.0	gcc-linaro-5.1-r2015.08	1.9	↑	4.4	↑	↑	WS1.0/1.1	-	α2a	α2	-	↑	↑	-	
v2.8.0	16/4E	↑	↑	↑	↑	↑	↑	↑	↑	-	↑	↑	-	α2	α2	α	
									-	WS	↑	-	-	-	-	-	
v2.9.0	16/5E	↑	↑	↑	↑	↑	↑	↑	↑	↑	↑	↑	α2	↑	↑	↑	
v2.10.0	16/6E	↑	gcc-linaro-5.2-r2015.11	↑	↑	4.6	64	↑	↑	↑	↑	↑	↑	↑	↑	↑	Internal
v2.11.0	16/7E	↑	↑	↑	↑	4.6	↑	↑	↑	↑	↑	↑	↑	↑	↑	↑	Internal
v2.12.0	16/8E	↑	gcc-linaro-5.2-r2015.11	↑	↑	4.6	64	↑	WS1.1	-	↑	↑	-	↑	↑	↑	
									-	↑	β	-	β	β	β	β	
v2.13.0	16/9E	↑	↑	↑	↑	↑	↑	↑	↑	↑	↑	↑	↑	↑	↑	↑	Internal
v2.14.0	16/10E	↑	↑	↑	↑	↑	↑	↑	↑	↑	↑	↑	↑	↑	↑	↑	Internal
v2.15.0	16/11E	↑	↑	↑	↑	TBD***	↑	↑	↑	↑	↑	↑	↑	↑	↑	↑	Internal
v2.16.0	16/12E	TBD*	TBD**	TBD**	TBD**	TBD***	↑	↑	↑	↑	↑	↑	↑	↑	↑	↑	Internal
v2.17.0	17/1E	TBD*	TBD**	TBD**	TBD**	TBD***	↑	↑	WS1.1/WS2.0	↑	↑	β	↑	↑	↑	↑	
v2.23.0	17/7E	↑	↑	↑	↑	↑	↑	↑	↑	WS/CS	Final	Final	Final	Final	Final	Final	

*) Assume to support Yocto v2.2.

***) Follows by the components version which support in Yocto project.

***) Kernel version of the candidate for ltsi-2017

R-CAR GEN3 LINUX SOFTWARE DELIVERY FLOW

2016.4.21 Updated

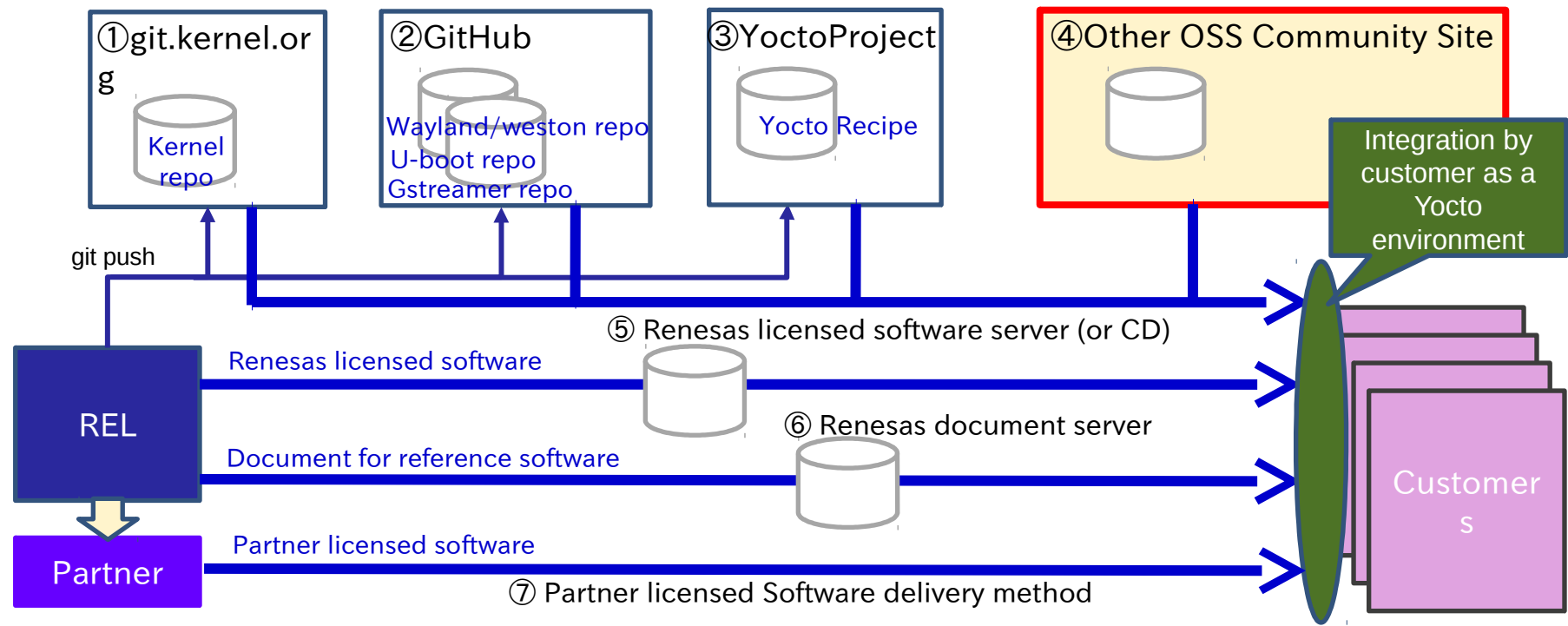

No	Delivery	note
1	git.kernel.org/renesas-bacport	
2	GutHub(https://github.com)	
3	YoctoProject (git://git.yoctoproject.org/meta-renesas/)	
4	Other OSS Community Site	We will use the software of these community site as it is. (Linaro etc ,)
5	Renesas licensed software server (or CD)	Under consideration
6	Renesas Document server	Under consideration

COMPONENT LIST OF GEN3 LINUX

description

Item	Function	Module Name	Layer	License	Code	License Fee	Delivery	Yocto	note
ex	Initial Program loader	IPL	-	BSD	Source	FOC	2	√	

The contents of each item are indicated below.

Layer/OS : “Layer/OS” indicates the software work layer or OS.

License : “License” indicates the original license holder of the software. Both Renesas and Partner have distribution right of it. If the software is OSS, “License” means the license form and the restriction of software distribution.

Code : “Code” indicates the software delivery form, which are “Source code” or “Binary form”.

License Fee : “License Fee” indicates the charged software. “charged” means the license agreement is necessary for use the software between customer and Renesas or Partner. “FOC” means free of charge.

Delivery : “Delivery” indicates the software delivery method. See Page.8 for details.

Yocto : “Yocto” indicates the Yocto Recipe coverage. If checked(= “√”), it means that the software will be integrated by “Yocto Recipe” distributed by Yocto Project.

*1) Delivery number indicates as below.

- 1: git.kernel.org/renesas-bacport, 2: [GitHub\(https://github.com\)](https://github.com), 3: YoctoProject ([git://git.yoctoproject.org/meta-renesas/](https://git.yoctoproject.org/meta-renesas/)), 4: Other OSS Community Site (Linaro, etc), 5: Renesas licensed software server (or CD), 6: Renesas Document server, 7: Partner licensed Software delivery method

COMPONENT LIST OF GEN3 LINUX BSP & IPL

Item	Function	Module Name	Layer	License	Code	License Fee	Delivery	Yocto	note
u-boot	UART,Ethernet,Timer,USB,SD,eMMC	u-boot patch	-	GPLv2	Source	FOC	2,6	√	
Linux BSP Drivers	UART	SCIF/HSCIF Driver	Kernel	GPLv2	Source	FOC	1,6	√	
	SPI	MSIOF driver							
	Watchdog	RWDT Driver							
	Ethernet	Gigabit Ethernet driver							
	Display	Display driver							
	USB3.0	xHCI USB Host driver							
	USB2.0	OHCI/EHCI USB Host driver							
	USB Function	USB Function Driver (USB2.0)							
	DMA Engine	DMA Engine Driver							
	SD Card / eMMC	SD/MMC Driver							
	Audio	Audio Driver							
	I2C	I2C Driver							
	GPIO	GPIO Driver							
	SATA	SATA Driver							
	PCIe	PCIE Driver							
	Thermal Sensor	Thermal Sensor Driver							
	PTP Clock	PTP Clock Driver							
PWM	PWM Driver								
Video Input	Video Capture Driver								
QoS driver	QoS Driver								
Item	Function	Module Name	Layer	License	Code	License Fee	Delivery	Yocto	note
IPL	Initial Program loader	IPL	-	BSD	Source	FOC	2,6	√	

COMPONENT LIST OF MULTIMEDIA PACKAGE FOR GEN3 LINUX (1/4)

Item	Function	Software Name	Layer	License	Code	License Fee	Delivery	Yocto	note
Multimedia Reference software for Linux									
Video processing	VSP extension for V4L2	V4L2 Driver (VSP Mem to Mem)	Kernel	GPLv2/MIT	Source	FOC	2	√	patch
	Resize , Blend and Rotation, Interlace to Progressive Conversion	VSP Manager IF	User	MIT	Source	FOC	2,6	√	
		VSP/FDP Manager	Kernel	GPLv2/MIT	Source	FOC	2	√	
		VSP Driver							
	FDP Driver								
V4L2 I/F	V4L2-I/F patch for CMS	User	MIT	Source	FOC	2	√	patch	
Display subsystem	DRM I/F	DRM-I/F patch for CMS	User	MIT	Source	FOC	2	√	patch
	VSP-DU Driver	VSP-DU Driver patch for CMS	Kernel	GPLv2/MIT	Source	FOC	2	√	patch
Window System (Wayland/Weston)	Renderer	Weston v4l2-renderer	User	MIT	Source	FOC	2	√	plug-in
	Memory Management for KMS	Generic Buffer Management Library for Linux Wayland	User	MIT	Source	FOC	2	√	patch
	Wayland extension protocol (wayland-kms)	Wayland extension protocol Library	User	Apache-2.0/MIT	Source	FOC	2	√	patch
System Control	Memory Manager	Memory Manager IF	User	MP3/WMA	Source	FOC	2,6	√	
		Memory Manager	Kernel	GPLv2/MIT	Source	FOC	2	√	
		gst-omx	User	LGPLv2.1	Source	FOC	2,6	√	*1)
	Codecstreamer Plug-In for Video/Audio								

COMPONENT LIST OF MULTIMEDIA PACKAGE FOR GEN3 LINUX (2/4)

Item	Function	Module Name	Layer	License	Code	License Fee	Delivery	Yocto	note
Graphics	OpenGL ES3.1 (H3)	R8A7795 GX6650 OpenGL ES3.1 Library for Linux (including Wayland WSEGL Library)	User	Proprietary	Binary	charged	7	√	*2)
		R8A7795 GX6650 Device Driver for Linux	Kernel	GPLv2/MIT	Source	FOC	7	√	
	OpenGL ES3.1 (M3)	R8A7796 GX6250 OpenGL ES3.1 Library for Linux (including Wayland WSEGL Library)	User	Proprietary	Binary	charged	7	√	*2)
		R8A7796 GX6250 Device Driver for Linux	Kernel	GPLv2/MIT	Source	FOC	7	√	

Item	Function	Module Name	Layer	License	Code	License Fee	Delivery	Yocto	note
Graphics	OpenGL ES3.1 (H3)	R8A7795 GX6650 GLSL Offline Compiler for Linux	Tool on PC	IMG	Binary	FOC	7	-	*2)
	OpenGL ES3.1 (M3)	R8A7796 GX6250 GLSL Offline Compiler for Linux	Tool on PC	IMG	Binary	FOC	7	-	*2)

*1) Graphics SW will be provided and supported by ASI. So the Graphics SW will be a suggestion from ASI who provide about a cost.

*2) There are some conditions to use this software. Please contact sales.

COMPONENT LIST OF MULTIMEDIA PACKAGE FOR GEN3 LINUX (3/4)

Item	Function	Software Name	Layer	License	Code	License Fee	Delivery	Yocto	note	
OMX Common	OMX	OMX Media Component Common Library for Linux	User	Proprietary	Binary	charged	5	√		
	OMX	OMX Media Component Video Decoder Common Library for Linux								
Video Decode	H.264/AVC	OMX Media Component H.264 Decoder Library for Linux								
	H.265/HEVC	OMX Media Component H.265 Decoder Library for Linux								
	MPEG-4	OMX Media Component MPEG4 Decoder Library for Linux								
	MPEG-2	OMX Media Component MPEG2 Decoder Library for Linux								
	VC-1	OMX Media Component VC-1 Decoder Library for Linux								
	DivX	OMX Media Component DivX Decoder Library for Linux								*1)
	Real Video	OMX Media Component Real Video Decoder Library for Linux								*1)
	VP6	OMX Media Component VP6 Decoder Library for Linux							User	Proprietary
	VP8	OMX Media Component VP8 Decoder Library for Linux	by order							
Sorenson H.263	OMX Media Component Sorenson H.263 Decoder Library for Linux	by order *1)								
Video Encode	H.264/AVC	OMX Media Component Video Encoder Common Library for Linux	User	Proprietary	Binary	charged	5	√		
		OMX Media Component H.264 Encoder Library for Linux								
Common		UVCS Driver for Linux	Kernel	GPLv2/MIT	Source	FOC	5	√		

*1: There are some conditions to use this software. Please contact sales.

COMPONENT LIST OF MULTIMEDIA PACKAGE FOR GEN3 LINUX (4/4)

Item	Function	Software Name	Layer	License	Code	License Fee	Delivery	Yocto	note							
Audio Common	OMX	OMX Media Component Audio Common Library for Linux														
Audio Decode	HE-AACV2	OMX Media Component for aacPlus V2 Decoder Library for Linux	User	Proprietary	Binary	charged	5	√	*1)							
		aacPlus V2 Decoder Middleware Library for Linux														
	AAC-LC	OMX Media Component for AAC-LC Decoder Library for Linux														
		AAC-LC 2ch Decoder Middleware Library for Linux														
	MP3	OMX Media Component for MP3 Decoder Library for Linux														
		MP3 Decoder Middleware Library for Linux							*1)							
	WMA	OMX Media Component for WMA Standard Decoder Library for Linux														
		WMA Standard Decoder Middleware Library for Linux							*1)							
	Dolby Digital	OMX Media Component for Dolby(R) Digital Decoder Library for Linux														
		Dolby(R) Digital 5.1ch Decoder Middleware Library for Linux							*1)							
	FLAC	OMX Media Component for FLAC Decoder Library for Linux								User	Proprietary	Binary	charged			
									FLAC Decoder Software Library for Linux		new BSD	Source	FOC			
		ALAC							OMX Media Component for ALAC Decoder Library for Linux		User	Proprietary	Binary	charged		
									ALAC Decoder Software Library for Linux	Apache		Source	FOC			
Audio Encode	AAC-LC	OMX Media Component for AAC-LC Encoder Library for Linux	User	Proprietary	Binary	charged										
		conditions to use this software. Please contact sales. AAC-LC Encoder Middleware Library for Linux														

COMPONENT LIST OF OPTION SOFTWARE FOR GEN3 LINUX

Item	Function	Software Name	Layer	License	Code	License Fee	Delivery	Yocto	note
CMS	Color Management System	Basic Color Management Middleware for Linux	User	Proprietary	Binary	charged	5	√	
		VSP2 Dynamic Gamma Correction Middleware for Linux							
		CMM3 Basic Color Management Middleware for Linux							
		CMM3 Backlight Control Middleware for Linux							
DTV/DVD	DTV (ISDB-T)	ISDB-T DTV Software Package for Linux	User	Proprietary	Binary	charged	7	√	
		DTV Driver for Linux	Kernel	GPLv2/MIT	Source	FOC	7	√	
	DVD	DVD Core-Middleware for Linux	User	Proprietary	Binary	charged	7	√	*1)
		DVD Encryption Library	User	Proprietary	Binary	charged	5	-	*1)
		DVD Encryption Library	SecureOS	Proprietary	Binary	charged	5	-	*1)

*1: There are some conditions to use this software. Please contact sales.

COMPONENT LIST OF GEN3 LINUX SECURE PACKAGE (1/2)

Item	Function	Software Name	Layer/OS	License	Code	License Fee	Delivery	Yocto	note	
Security Board Support Package for Linux										
Secure	Security BSP	Secure Monitor	ARM Trusted Firmware BL31	Monitor	BSD	Source	FOC	4	√	*1)
			ARM Trusted Firmware BL31 patch					2	√	patch
	Secure OS	Secure OS	OP-TEE (including TEE Internal API)	Secure OS	BSD	Source	FOC	4	√	*2)
			OP-TEE patch					2	√	patch
	Secure Driver	Secure OS	SPI / HyperFlash Driver	Secure OS	BSD	Source	FOC	2,6	√	
			Timer Driver							
	Linux-side Driver		TEE Client API (including TEE Supplicant)	Linux	BSD	Source	FOC	4	√	*3)
			TEE Client API patch					2	√	patch
			OP-TEE Linux Driver	Linux	GPLv2	Source	FOC	4	√	*4)
			OP-TEE Linux Driver patch					2	√	patch
Secure library	Cryptographic IP Driver	SS6.3-Public Driver	Linux	GPLv2	Source	FOC	5	√		
		SS6.3-Secure Driver	Secure OS	Proprietary	Binary	FOC	5	√	*5)	
		SSPKA Driver								

*1) "ARM trusted firmware BL31" will be downloaded from "<https://github.com/ARM-software/arm-trusted-firmware>".

*2) "OP-TEE" will be downloaded from "https://github.com/OP-TEE/optee_os "

*3) "TEE Client API" will be downloaded from "https://github.com/OP-TEE/optee_client"

*4) "OP-TEE Linux Driver" will be downloaded from "https://github.com/OP-TEE/optee_linuxdriver "

*5) It is necessary the license agreement for use this software with Renesas.

COMPONENT LIST OF GEN3 LINUX SECURE PACKAGE (2/2)

Item	Function	Software Name	Layer/OS	License	Code	License Fee	Delivery	Yocto	note
Secure Tools	Secure Boot / Secure Debug Software	Secure Boot Signing Tool	Tool on PC	Proprietary	Binary	charged	5	-	*1)
		Secure Debug Signing Tool	Tool on PC	Proprietary	Binary	FOC	5	-	*2)
		Secure Storage Setup Tool for eMMC RPMB	T.B.D.	Proprietary	Binary	FOC	5	-	*3)

*1) Secure Boot Signing Tool is for Secure Boot execution, and used with Secure Boot Library. It is necessary the license agreement for use this software with Renesas.

*2) It is necessary the license agreement for use this software with Renesas.

~~*3) This tool generates an authentication key for eMMC PRMB area access and install it to eMMC.~~

APPLICATION NOTE OF MULTIMEDIA PACKAGE FOR LINUX

Item	Function	Software Name	Layer	License	Code	License Fee	Delivery	Yocto	note
R-Car Gen3 Ethernet AVB Application for Linux									
Ethernet AVB	File transfer and save	Simple Application	User	MIT	Source	FOC	5	-	
	Audio stream transfer and playback	Audio Application							
	Control stream transfer and playback	Control Application							
Item	Function	Software Name	Layer	License	Code	License Fee	Delivery	Yocto	note
ADSP Reference Plugin									
ADSP Framework	ADSP Reference Equalizer Plugin	ADSP Reference Plugin	ADSP	MIT	Source	FOC	2,6	-	
	ADSP Reference Renderer Plugin	ADSP Reference Plugin							
Item	Function	Software Name	Layer	License	Code	License Fee	Delivery	Yocto	note
Multimedia Application note									
CMS	Basic Color Management	Application note for Basic Color Management	User	MIT	Source	FOC	5		
	Dynamic Gamma Correction	Application note for Dynamic Gamma Correction for VSP							
	Backlight Control	Application note for Backlight Control for DU							

www.renesas.com

R-Car Gen3 development schedule (for General customer)

	WS	ES	CS	MP	note
R-Car H3 WS1.1	Now				
R-Car H3 WS2.0	2016/11/E	2017/6/E (2016/11/E)	2017/9/E (2017/6)	2018/3/E (2017/12)	
R-Car M3	Now	2016/8/E	2017/5/E	2018/3/E	
R-Car M3N	2017/3/E (2017/1/E)	2017/7/E (2017/3/E)	2018/2/E (2017/12/E)	2018/9	
R-Car E3	2017/7/E (2017/4/E)	2018/5/E (2017/Q3)	2018/8/E (2018/4/E)	2019/5/E (2018/Q4)	

() : Previous schedule